



AVAILABLE AIR ASSIST AIRLESS ORIFICES

PART NO.	ORIFICE SIZE	SPRAY ANGLE (DEGREES)	APPROX. PATTERN SIZE	PART NO.	ORIFICE SIZE	SPRAY ANGLE (DEGREES)	APPROX. PATTERN SIZE
36-207	0.007	20	4"	36-315	0.015	30	6"
36-309	0.009	30	6"	36-415	0.015	40	8"
36-409	0.009	40	8"	36-515	0.015	50	10"
36-311	0.011	30	6"	36-615	0.015	60	12"
36-411	0.011	40	8"	36-715	0.015	70	14"
36-511	0.011	50	10"	36-815	0.015	80	16"
36-213	0.013	20	4"	36-417	0.017	40	8"
36-313	0.013	30	6"	36-517	0.017	50	10"
36-413	0.013	40	8"	36-619	0.019	60	12"
36-513	0.013	50	10"	36-621	0.021	60	12"
36-613	0.013	60	12"				

Operation and Maintenance Instructions for *Cougar* Spray Guns

Operation

1. Connect air supply hose at handle of gun.
2. Connect material supply hose from pump to the gun fluid inlet.
3. The fluid shut-off knob locks the trigger and prevents gun operation when turned clockwise as far as possible.
4. Maximum pattern width is determined by tip selection. Turning the fan control knob counter clockwise will narrow the fan. Pattern is maximum when fan control is completely closed.
5. For HVLP compliance, do not exceed 15 psi air pressure at gun handle.

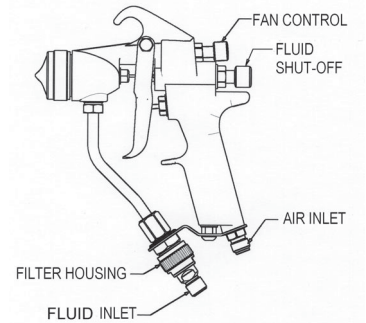

MAINTENANCE NOTE:

- **Complete gun disassembly is not recommended for normal cleaning and maintenance.**

IMPORTANT! Relieve gun fluid pressure to 0 psi before performing any maintenance.

10-113 Complete Gun Repair Kit

10-127 Gun Repair Kit (soft seals only)

Replacing needle cartridge assembly

1. Remove the trigger by removing both trigger screws (17).
2. Remove fluid control knob (27) by turning counter clockwise. Remove return spring (25) and spring seat (26).
3. Using a 5/8" open end wrench or socket, remove rear bushing (16). Gasket (15) can be reused.
4. Using a 3/8" wrench remove the needle seal body (27). The needle seal cartridge (27) can be removed through the back of the gun.
5. When replacing spring seat, the long end goes inside spring for operating pressures below 1000 PSI. For operating pressures above 1000 PSI, the short end of the spring seat goes into the spring.

Replacing gun seat

1. Remove air cap (11) and tip (12). Using 1/2" socket, remove fluid nozzle body (1).
2. Using an 1/8" rod, push both the seat (2) and seat retainer (3) out of the nozzle body.

Replacing gun filter

1. Using a 3/4" open end wrench, remove filter retainer nut (33) and separate the upper and lower filter housings exposing the filter. It is not necessary to disconnect the fluid hose to change the filter. NOTE: The gun is equipped with a 100 mesh filter as standard. 60 mesh filters are also available.

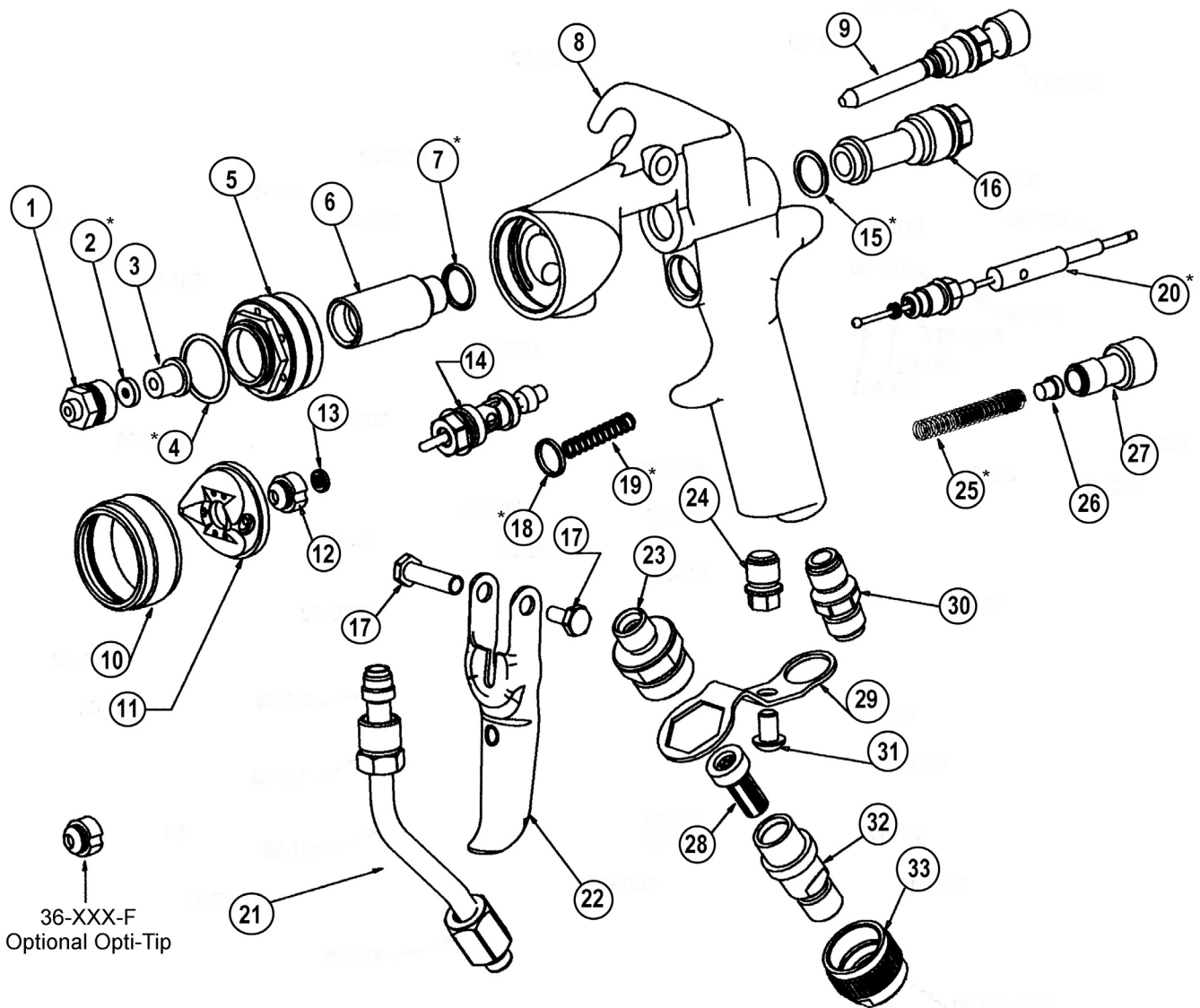

*Included in repair kit # 10-113

ITEM NO.	PART NO.	DESCRIPTION	ITEM NO.	PART NO.	DESCRIPTION
1	66-104	Nozzle Body	19	61-1003	Air Valve Spring
2	66-105	Seat	20	66-130	Needle Seal Cartridge**
3	66-110	Seat Retainer	21	66-115	Fluid Tube Assembly
4	98-8019	O-Ring*	22	60-2102	Trigger
5	66-103	Air Cap Adapter	23	66-121	Upper Filter Housing
6	66-102	Nozzle Carrier	24	66-119	Handle Plug
7	98-8014	O-Ring*	25	60-208	Spring
8	66-101	Gun Body	26	66-137	Spring Seat
9	60-1505	Fan Control	27	60-202	Fluid Control Knob
10	21-1001	Air Cap Ring	28	66-125	Filter (100 mesh standard)
11	26-101	Air Cap		66-124	Filter (60 mesh optional)
12	36-XXX	Fluid Tip	29	66-118	Bracket
13	98-8007	O-Ring*	30	60-104	Air Inlet
	36-100	Tip Strainer (Optional)	31	98-0186	Screw
14	60-1520	Air Valve	32	66-122	Filter Housing, Lower
15	60-119	Gasket	33	66-123	Filter Retaining Nut
16	60-201	Rear Bushing	Repair Kits		
17	60-1033	Trigger Pivot Assembly	10-127	Gun Repair Kit (soft seals only)	
18	60-125	Air Valve Gasket	10-113	Repair Kit	

Cougar Gun Air Consumption

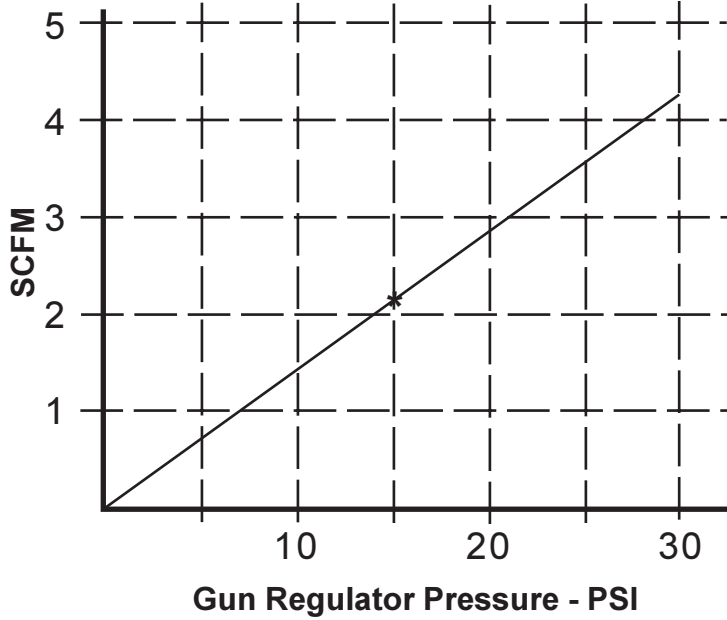

*Max pressure for HVLP

C14 AAA Pump Air Consumption

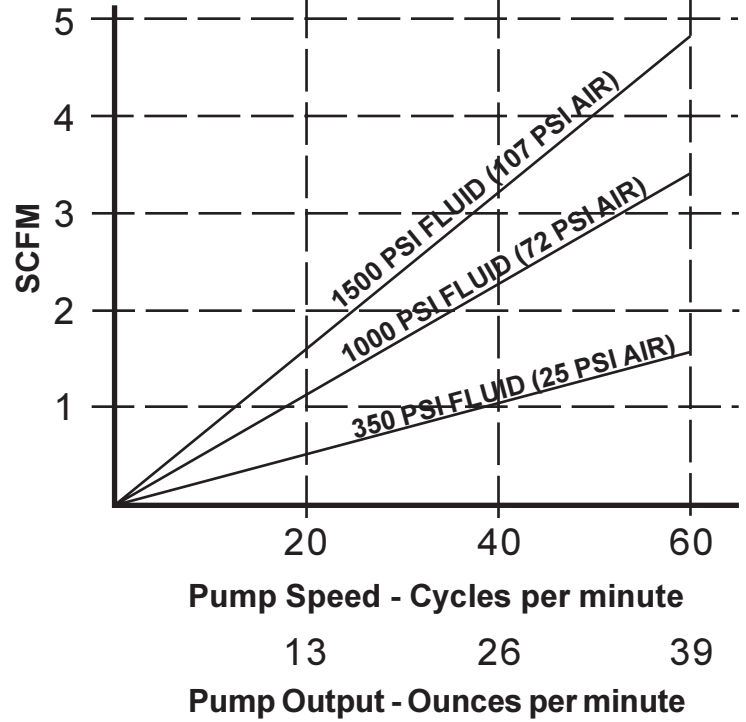

Compressed Air Requirements

Minimum compressor size will vary with the application. Air requirements for the gun and pump must be added together for total air requirements.

Example: Gun Regulator Setting 25 psi, scfm = 3.5
 Pump fluid pressure is 1000 psi and cycle rate is 30, scfm = 1.75
 Minimum compressor requirement: 3.5+1.75 = 5.25 scfm

Fluid Tip Flow Rate Chart (Fluid oz/min.)

Tip Size	Pressure (psig)							
	350		700		1000		1500	
	Light Materials	Heavy Materials	Light Materials	Heavy Materials	Light Materials	Heavy Materials	Light Materials	Heavy Materials
0.007	3	---	4	---	5	---	6	---
0.009	5	---	8	---	9	---	11	---
0.011	8	---	11	---	13	---	16	---
0.013	10	---	14	---	17	---	21	---
0.015	13	---	18	---	22	---	27	---
0.017	17	13	24	18	29	22	35	27
0.019	21	16	30	23	36	27	44	33
0.021	27	21	38	29	45	35	56	43

Note: Values are approximate and will vary depending on actual material viscosity.